

HITACHI® POWER TOOLS

Construction Nailers

For Clipped Head, Strip & Paper-Collated Nails



NR83AA

Lightweight nailer provides speed and accuracy for floor or wall framing and standard heavy-duty general construction. Nose designed for toenailing; one-piece extruded aluminum magazine. Accept paper-collated, clipped head, strip nails; smooth or ring shank nails; .113"/.120"/.131" shank dia. Air pressure 70 to 120 psi; 3/8" air hose inlet. Optional flush-drive attachment, remote fire parts kit, and single shot set available.

No.	Model No.	Load Cap.	Nail Lgth. In.	Ht. In.	Wdth. In.	Lgth. In.	Wt. Lbs.
/990NR83AA	NR83AA	78-84*	2-3 1/2	14 3/16	4 1/4	16 1/2	7.9

*Two strips.

HITACHI® POWER TOOLS

Construction Nailers

Angled



NV83A

Full head. Standard contact trip trigger. Built-in toenail push lever. Depth-drive adjustment for siding applications. Open nose. Plastic shield deflects wire collation. Accept flat, wire-collated, coil nails. Air pressure requirements 70 psi to 120 psi. Hose air inlet 3/8" Nail capacity 200 to 300.

Nailers

No.	Model No.	Ht. In.	Wdth. In.	Lgth. In.	Wt. Lbs.
/990NV83A	NV83A	13 1/16	5 1/32	11 1/32	7.7

Accessories

No.	Desc.
876762	Single Trip Trigger Mechanism
878223	Remote Fire Parts Kit

HITACHI® POWER TOOLS

Construction Nailers

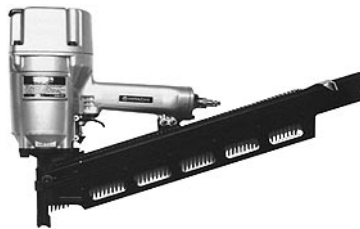

NR83A

Lightweight 1-hand operation provides speed of up to 3 nails/sec. For floor or wall framing, subflooring, sheathing, fencing and general duty applications. Nose designed for toenailing. Accept plastic-coated strip nails; smooth, screw or ring shank nails; .113", .120" and .131" shank diameter. Air pressures 70 psi to 120 psi. 3/8" air hose inlet. Optional flush-drive attachments, flush-drive push levers, remote fire parts kits, and single shot sets available.

No.	Model No.	Load Cap.	Nail Lgth. In.	Dim., In.	Wt. Lbs.
/990NR83A	NR83A	64-70*	2-3 1/4	13 3/8 4 3/32 22	7.9

*2 strips.

There's just not enough space to list all of the material and services we can offer you. Let us know about your problems.

HITACHI® POWER TOOLS

Finish Nailers

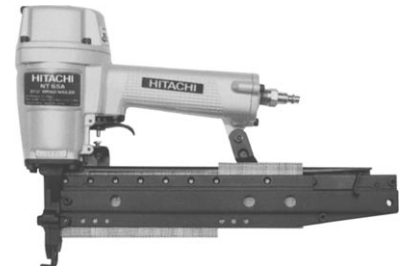

No. NT65A. Accept 16-ga. brads with lengths from 1" to 2 1/2". Major components constructed of metal alloy. Adjustable drive depth. Rubber no-mar push lever attachment. Air pressure requirements 70 psi to 120 psi. Hose air inlet 3/8". Nail capacity 150.



No. NT50AD. Ultra light. Leather hand grip. Deflects exhaust 360°. Adjustable drive depth. Lip length 7/8". Rubber no-mar push lever attachment. Accept 18-ga. brads with lengths from 1" to 2". Includes plastic carrying case. Metal alloy construction. Air pressure requirements 70 psi to 120 psi. Hose air inlet 3/8". Nail capacity 100.

No.	Model No.	Ht. In.	Wdth. In.	Lgth. In.	Wt. Lbs.
/990NT65A	NT65A	10	3	15	4.6
/990NT50AD	NT50AD	9 3/8	2 1/16	9 1/4	2.5

HITACHI® POWER TOOLS

Roofing Nailers
Coil - Wire Collation



NV45AB

Steel body. Adjustable shingle guide for accuracy. Depth of drive adjustable. Carbide-tip push lever. Rubber safety valve cover. Air hose inlet 3/8". Wt. 5.5 lbs.

Model No.	Nail No.	Cap.	Ht. psi	Wdth. In.	Lgth. In.	Wt. Lbs.
/990NV45AB	NV45AB	120	70-120	10 3/8	4 7/8	11 1/2

HITACHI® POWER TOOLS

Finish Nailers
Angled



NT65AA

Lightweight. High power rating. Long nail drive capacity into hard wood. Adjustable 360° exhaust. Can nail in tight places. Drive depth adjustment ensures accurate nailing depth. E-Z clear nose.

Model No.	Dim., In.	Wt. Lbs.	Air Press. psi	Nail Cap.
/990NT65AA	NT65AA 13.5 3.2 12	4.2	70-120	100

HITACHI® POWER TOOLS

Construction Nailers
For Wire Collated Nails



NV50A1

Accept wire-collated coil nails available in lengths of 1 1/4", 1 1/2", 1 3/4" and 2" with width of .083"; in smooth, ring and screw shank styles. Have plastic wire deflector and slip-proof grip.

Angled magazine allows nailing in tight spaces. Open magazine canister shows nail quantity. Have air pressure of 70 to 120 psi and hose air inlet of 3/8". Optional features include remote fire parts kit, single trip trigger mechanism and power set.

Model No.	Load No.	Ht. Cap.	Ht. In.	Wdth. In.	Lgth. In.	Wt. Lbs.
/990NV50A1	NV50A1	400	10 3/8	4 3/4	11 1/2	4.2

HITACHI® POWER TOOLS

Concrete Nailers



NC65AC

Reposition over nail if not fully driven. Reciprocating drive. One-touch load switch. Adjustable drive depth. Can use on steel sheet. Include clear plastic nail magazine and plastic case. Accept diamond point or ballistic point hardened steel nails. Air pressure requirements 70 psi to 120 psi. Hose air inlet 3/8". Nail capacity 54.

Model No.	Ht. In.	Wdth. In.	Lgth. In.	Wt. Lbs.
/990NC65AC	NC65AC 14 1/16	3 25/32	9 1/16	5.1

HITACHI® POWER TOOLS

Finish Staplers

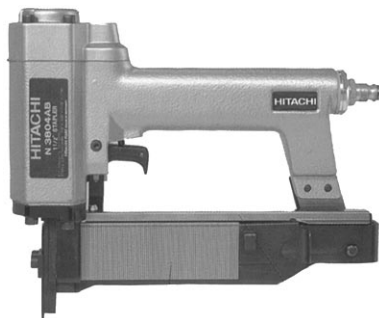

N3804AB

Narrow crown. Major components constructed of metal alloy. Compact design. Exhaust muffler reduces noise. Open magazine design. Easy loading. Accept 18-ga. staples in lengths from 1/2" to 1 1/2". Use 1/4" narrow crown staples. Air pressure requirements 70 psi to 120 psi. Hose air inlet 3/8". Staple capacity 125.

Model No.	Ht. In.	Wdth. In.	Lgth. In.	Wt. Lbs.
/990N3804AB	N3804AB 8	2 7/32	9 23/32	2.9

HITACHI® POWER TOOLS

Construction Staplers

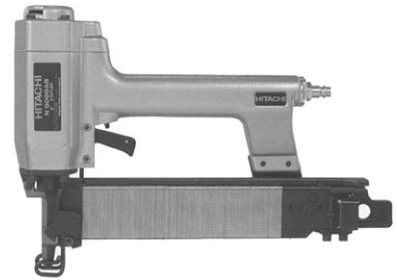

N5008AB

Standard crown. Major components constructed of metal alloy. Exhaust muffler reduces noise. Easy loading. Quick clear jam release. Open magazine design. Accept 16-ga. staples with lengths of 1" to 2" and 7/16" width. Air pressure requirements 70 psi to 120 psi. Hose air inlet 3/8". Staple capacity 156.

Model No.	Ht. In.	Wdth. In.	Lgth. In.	Wt. Lbs.
/990N5008AB	N5008AB 9 5/8	2 3/4	4 7/16	5.5

HITACHI® POWER TOOLS

Roofing Staplers

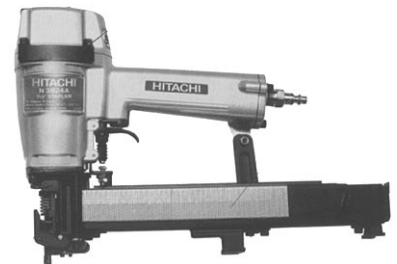

N3824A

Wide crown. Major components constructed of metal alloy. Steel body wear protector. Open magazine design. Quick clear jam release. Adjustable depth drive. Carbide-tipped push lever. Feature shingle guide for staple placement, body protector and safety valve. Accept 16-ga. staples from 1/2" to 1 1/2" long with 1" width. Air pressure requirements 70 psi to 120 psi. Hose air inlet 3/8". Staple capacity 150.

Staplers

Model No.	Ht. In.	Wdth. In.	Lgth. In.	Wt. Lbs.
/990N3824A	N3824A 9 13/32	3 5/32	14 7/32	5.3

Accessories

No.	Desc.
878223	Remote Fire Parts Kit
876762	Single Trip Trigger Mechanism
877908	Power Set

TECH FASTENERS
Brad Nailers

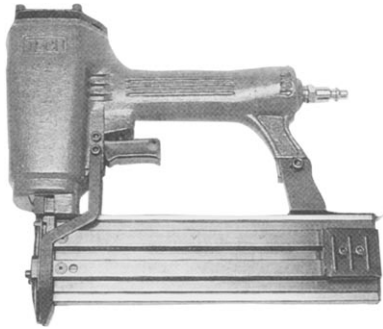

1503

Drive "J" series 18-ga. brads 3/4" to 2". Use to finish trim, molding, furniture manufacturing, picture frames, cabinets, woodworking, crafts. Carrying case included.

No.	Model No.	Mag. Cap.	Wt. Lbs.
/990UB18200AK	1503	100	3.6

TECH FASTENERS
Brad Nailers

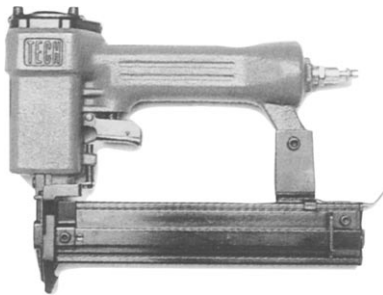

1504

Drive "J" series 18-ga. brads 1/2" to 1 1/4". For furniture moldings, drawers, picture frames, cabinets, woodworking, crafts. Include carrying case and brads.

No.	Model No.	Mag. Cap.	Wt. Lbs.
/990UB18125AK	1504	100	2.9

TECH FASTENERS
Finish & Furniture Staplers

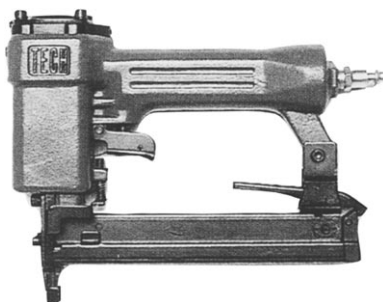

1508

Drive 1/4" crown "L" series staples from 1/2" to 1". Use to finish trim, molding, furniture manufacturing, cabinet work, casebacks, soffits, crafts. Include free carrying case.

No.	Model No.	Mag. Cap.	Wt. Lbs.
/990US1814CK	1508	100	2.8

ATRO®
Pneumatic Fasteners
Plier - Long Jaw



P-110

For mattress construction, fastening covers, attaching carpeting and cardboard cylinders. Use 110 staples (11.5 mm). Working pressure 80 psi, 5 bars to 80 psi, 6 bars. Magazine capacity 200.

No.	Model No.	Wt. Lbs.
/981911-2520	P-110	3.3

SALCO®
Electronic Staplers



"Ganging" capability for simultaneous multiple stapling. Impact control allows clean, tight stapling from 2 to 45 sheets on equivalent materials. Durable heads for high volume use.

No.	No.	Lgth. In.	Wdth. In.	Ht. In.	Wt. Lbs.
/980105-001	980105-001	9 3/4	4	10 1/4	8.5

NORTH AMERICAN FASTENER CORP.
Pneumatic Staplers
Prebena®



For staple sizes 5/32" to 5/8". Operating pressure 57 psi to 87 psi.

No. 1m-A-16. Has exhaust silencer. For upholstery, decorating and insulation applications. Wire dimension .025"x.037". Staple crown .507". Wt. 2 lbs. 4 oz.

No. 1m-V-16. Type V from 1/4"-9/16". Wire size .024"x.030". Crown .354". Wt. 2 lbs. 7 oz.

No.	Model No.	For Staple Type
/9901MA16	1m-A-16	A
/9901MV16	1m-V-16	V

CARTON CLOSING
Hand Clinchers
Model HC



For low volume packaging lines or warehouse applications with manual stapling applications where compressed air is unavailable. One-piece staple pusher and magazine. Spring loaded, removable. Independent clinch control and penetration adjustment. Built-in handle. Wt. 4 lbs. 5 oz.

No. HC-C. Accepts 1/2", 5/8" and 3/4" staples.
No. HC-A. Accepts 1/2", 5/8", 3/4" and 7/8" staples.

No.	Staple Type	Crown Size In.	For Staples In.	Staple Cap.
/981618-2111	HC-C	1 1/4	5/8	150
/981618-2121	HC-C	1 1/4	3/4	150
/981618-2011	HC-A	1 3/8	5/8	100
/981618-2021	HC-A	1 3/8	3/4	100

CARTON CLOSING

Air Clinchers
Model AC

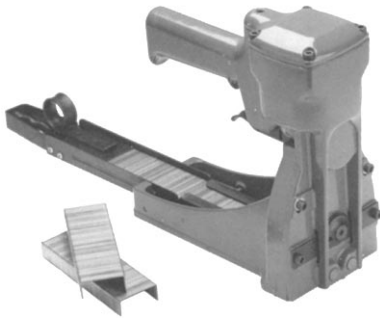

For low to moderate volume packaging lines with manual stapling applications where awkward position unavoidable. Use preformed stick staples. One-piece staple pusher and magazine. Spring loaded, removable. Independent clinch control and penetration adjustment. Require .05 cu. ft. air/cycle at 80 psi. Wt. 5 lbs. 9 1/2 oz.

No. AC-C. Accepts 1/2", 5/8" and 3/4" staples.

No. AC-A. Accepts 1/2", 5/8", 3/4" and 7/8" staples.

No.	Staple Type	Crown Size In.	For Staple In.	Staple Cap.
/981618-2311	AC-C	1 1/4	5/8	150
/981618-2321	AC-C	1 1/4	3/4	150
/981618-2511	AC-A	1 3/8	5/8	100
/981618-2521	AC-A	1 3/8	3/4	100
/981618-0231	AC-A	1 3/8	7/8	100

CARTON CLOSING

Roll Clinchers
Model RC1000



Pneumatic. For moderate volume packaging lines with manual stapling applications up to 250 cartons before reload. Use 1000 roll staple coils. One-piece staple pusher and magazine. Spring loaded, removable. Independent clinch control and penetration adjustment. Accept 5/8" and 3/4" staples. Require .05 cu. ft. air/cycle at 80 psi. Wt. 7 lbs. 12 oz.

No.	No.	Staple Type	Crown Size In.	For Staple In.
/981618-2740	1981618-2740	RR1	1 1/4	5/8
/981618-2750	1981618-2750	RR1	1 1/4	3/4

CARTON CLOSING

Foot Clinchers
Model FC6



For carton bottoming of less than 50 cartons per hour or where compressed air is unavailable. Welded steel construction. One-piece staple pusher and magazine. Compact design. Open style head. Low foot pedal. Capacity 200 staples. Throat opening 15". Post height 39".

No. FC250C. Accepts 1/2" to 3/4" staples.

No. FC250A. Accepts 1/2" to 7/8" staples.

No.	Model No.	Staple Type	Crown Size In.
.....	FC250C	C	1 1/4
.....	FC250A	A	1 3/8

CARTON CLOSING

Pneumatic Clinchers
Model PC6



Foot valve operated bottomer for requirements excedding 50 cartons per hour. Include filter and regulator unit. Welded steel construction. One-piece staple pusher and magazine. Compact design. Open style head. Low foot pedal. Capacity 200 staples. Throat opening 15". Post height 39". Air required .09 cu. ft./cycle at 80 psi.

No. PC200C. Accepts 1/2" to 3/4" staples.

No. PC200A. Accepts 1/2" to 7/8" staples.

No.	Model No.	Staple Type
...PC200C	PC200C	C
...PC200A	PC200A	A

CARTON CLOSING

Side Arm Clinchers

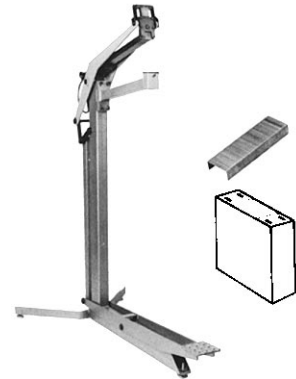

For bottoming assembly of corrugated cardboard trays and caps. Welded steel construction. One-piece staple pusher and magazine. Compact design. Open style head. Low foot pedal. Both foot and pneumatic models available. Pneumatic custom height units available on special order. Capacity 200 staples. Throat opening 15". Post height 39".

No. PC200AS. Accepts 1/2" to 3/4" staples.

No. FC200AS. Accepts 1/2" to 7/8" staples.

No. PC250CS. Accepts 1/2" to 3/4" staples.

No. FC250CS. Accepts 1/2" to 7/8" staples.

No.	Model No.	Desc.	Crown Size In.
...PC200AS	PC200AS	Foot	1 1/4
...FC200AS	FC200AS	Foot	1 3/8
...PC250CS	PC250CS	Pneumatic	1 1/4
...FS250CS	FC250CS	Pneumatic	1 3/8

PNEUMATIC FASTENERS



980321

Hand Tackers

No.	Model No.	Desc.	Use Staple No.
/980321	980321	Bostitch PC4000 1/4"-9/16" Leg Lgths.	STCR 5019, JK694



980028

Continued on next page

Continued from previous page

Swing Hammers

No.	Model No.	Desc.	Use Staple No.
/980028	980028	Rapid A11, 1/4"-3/8" Leg Lgths.	A11, PF, T50
/980020	980020	Bostitch H2B HD, 1/4"-3/8" Leg Lgths.	SHCR 5019



980199



980200



980160

Pliers

No.	Model No.	Desc.	Use Staple No.
/980100	980100	P3-BL	SP 19 1/4"
/980199	980199	P694 (R-31), Blunt, 1/4"-1/2 Leg Lgths.	JK 694, STCR 5019
/980200	980200	P694, Pierce Pt., 1/4"-1/2 Leg Lgths.	JK 694, STCR 5019
/980201	980201	P210, 1/4"-5/16" Leg Lgths.	210/6, 210/8
/980202	980202	P700 Ace, Undulated Type	Ace 700C/6
/980HFP9	980HFP9	Fencing Hog Ring	09AL25
/980140	980140	P6-6, 1/4"-3/8" Leg Lgths.	STH 2619
/980150	980150	P6-8, 1/4"-3/8" Leg Lgths.	STH 5019 (Old), STCR 5019 (New)

No.	Model No.	Desc.	Use Staple No.
/980160	980160	P6-8F, Forked, Bag, 1/4"-3/8" Leg Lgths.	STH 5019
/980180	980180	P6-12, 1/4"-3/8" Leg Lgths.	STH 19
/980203	980203	P7, Hog Ring	SR8-062

Accessories

No.	Model No.	Desc.
/980028P	980028P	Pusher Spring for R11, SDH20

LIGHTWIRE STAPLES



Following for use in A19 (Rapid R19) stapler.

No.	Model No.	Size In.	Box Qty.	Box/ Ctn.
/960A19625	A19-6	1/4	5M	20

Following for use in Arrow T-50, SDH20, SDT20, A11 (Rapid R11), Roberts and Senco H06 staplers.

No.	Model No.	Size In.	Box Qty.	Box/ Ctn.
/960T5025	T-50 (85504)	1/4	5M	20
/960T5031	T-50 (85505)	5/16	5M	20
/960T5037	T-50 (85506)	3/8	5M	20
/960T50D37	T-50 (86506)	3/8	5M	20
/960T5050	T-50 (85508)	1/2	5M	20
/960T5056	T-50 (85509)	9/16	5M	20

Following for use in Atro 7, Senco C, Empire 7, JK 670 and BEA 71 staplers.

No.	Model No.	Size In.	Box Qty.	Box/ Ctn.
/960107-0400	7/6 (C-02)	5/32	10M	20
/960107-0600	7/6 (C-04)	1/4	20M	10
/960107-0600PRE	7/6 (V-6, C-04)	1/4	10M	28/20
/960107-1000INT	7/10 (V-10, C-06)	3/8	10M	20
/960107-1000SS	Stainless Steel	3/8	10M	20
/960107-1200INT	7/12 (V-12, C-08)	1/2	10M	20
/960107-1400	7/14 (V-14, C-09)	9/16	10M	20

Following for use in Atro 80, Haubold 800, BEA 80, Empire 8 and JK 680 staplers.

No.	Model No.	Size In.	Box Qty.	Box/ Ctn.
/960180-0400	804 (A-04)	5/32	20M	30
/960180-0600	806 (A-6)	1/4	20M	30
/960180-1000	810 (A-10)	3/8	10M	18
/960180-1200	812 (A-12)	1/2	10M	15
/960180-1400	814 (A-14)	9/16	10M	15

Following for use in Atro 93, BEA 97, JK 690 and Senco W staplers.

No.	Model No.	Size In.	Box Qty.	Box/ Ctn.
/992197-1000	0-10 (97-10)	3/8	10M	20
/992197-1200	0-12 (97-12)	1/2	10M	20
/992197-1400	0-14 (97-14)	9/16	7.5M	20
/992197-1900	0-19 (97-19)	3/4	5M	20
/992197-2500	0-25 (97-25)	1	5M	20

Following for use in Bostitch staplers.

No.	Model No.	Size In.	Box Qty.	Box/ Ctn.
/960STCR501925	FB-6 (JK694/6)	1/4	5M	20/30
/960STCR501937	FB-10 (JK694/9)	3/8	5M	20

No.	Model No.	Size In.	Box Qty.	Box/ Ctn.
/960STCR501950	FB-12 (JK694/12)	1/2	5M	15
/960STCR261925	60/6	1/4	5M	50
/960STCR261937	60/9	3/8	5M	40
/960STCR261950	60/12	1/2	5M	20
/960STH501925	310/6	1/4	5M	20
/960STH501937	310/9	3/8	5M	20
/960STH261925	...	1/4	5M	50
/960STH261937	...	3/8	5M	40
/960SHCR501925	JK711/6	1/4	5M	50
/960SHCR501937	JK711/9	3/8	5M	20
/960SB10302037	Bostitch P50	3/8	2.4M	20
/960SB10302050	Bostitch P50	1/2	2.4M	10
/960SB10302062	Bostitch P50	5/8	2.4M	10
/960SBNK402325	Atro 84/6	1/4	10M	20
/960SBNK402337	Atro 84/10	3/8	10M	20
/960SBNK402350	Atro 84/12	1/2	10M	10
/960SBNK402356	Atro 84/14	9/16	10M	12/10
/960STCR211525	JK8/6	1/4	5M	80
/960STCR211537	...	3/8	5M	50
/960SBS1925	...	1/4	5M	100
/960SP1925	JK16/6	1/4	5M	40
/960SPS2525	JK752/6	1/4	10M	20
/960SPS2531	JK752/8	5/16	5M	20
/960SP302325	SPK, H1406	1/4	10M	40
/960SP302337	SPK, H1410	3/8	10M	20
/960SP302350	SPK, H1412	1/2	10M	20
/960SP302356	SPK, H1414	9/16	10M	20
/960SB501937	PW50, Senco F06 (JK685/10)	3/8	5M	20
/960SB501950	PW50, Senco F08 (JK685/12)	1/2	5M	20
/960SCCR10302037	...	3/8	2.5M	10
/960SCCR10302050	...	1/2	2.5M	10
/960SCCR2525	...	1/4	5M	20
/960SB705075	...	3/4	1M	20

Following for use in Duofast staplers.

No.	Model No.	Size In.	Box Qty.	Box/ Ctn.
/960508C25	D-6 (T64, BEA 95)	1/4	5M	20/30
/9605010C31	D-8 (T64, BEA 95)	5/16	5M	20
/9605010D31	36505	5/16	5M	20
/9605012C37	D-10 (T64, BEA 95)	3/8	5M	20
/9605016C50	D-12 (T64, BEA 95)	1/2	5M	20
/9605018C56	D-14 (T64, BEA 95)	9/16	5M	20/16
/9605020C62	T64, BEA 95	5/8	5M	15
/9605408C25	...	1/4	5M	20
/9605410C31	...	5/16	5M	20
/9605412C37	32506	3/8	5M	20
/9605416C50	32508	1/2	5M	20
/9605416D50	...	1/2	5M	20
/9605418D56	34509	9/16	5M	20
/960652887	KL9022 (JK)	7/8	5M	10

Following for use in Paslode staplers.

No.	Size In.	Box Qty.	Box/ Ctn.
/960W6050	1/2	5M	20
/960PN5025	1/4	10M	20
/960PN5037	3/8	10M	20
/960PN5050	1/2	5M	20
/960PN5062	5/8	5M	20
/960PN5075	3/4	5M	20
/960PS3050	1/2	10M	20
/960PW3037	3/8	10M	20

Following for use in Salco, Rapid and other staplers.

No.	Model No.	Size In.	Box Qty.	Box/ Ctn.
/960SECOB1250	682/12	1/2	5M	20
/960SECOB1662	682/16	5/8	5M	20
/9602106EBS25	210/6EBS	1/4	5M	100
/9602108EBS31	210/8EBS	5/16	5M	80

CARTON CLOSING

Fastener Accessories

For manual carton closure with wide crown staples on any packaging application.



Botomits. Supports inner flaps of carton placed over it.



Flap Lifters. Holds inner flaps on RSC style cartons.



Staple Pullers. Removes wide crown staples.

No.	Desc.
/981603-0303	9"x9" Botomit
.....	9"x18" Botomit
/981603-0202	Flap Lifter
/981603-0101	Staple Puller

CARTON CLOSING

Carton Closing Staples

Staples

No.	Desc.	Crown Type
/971602-4011	35/12-1/2	1 3/8" A Staple
/971602-5012	A 5/8	1 3/8" A Staple
/971602-5013	A 3/4	1 3/8" A Staple
/971602-4014	35/22-7/8	1 3/8" A Staple
.....	35/15-5/8	1 3/8" 20M/CTN
/971602-4031	32/12-1/2	1 1/4" C Staple
/971602-5032	C 5/8	1 1/4" C Staple
/971602-5033	C 3/4	1 1/4" C Staple
.....	32/15-5/8	1 1/4" 20M/CTN
/971601-5053	RR1-5/8 1M	1 1/4" Roll Staple
/971601-5054	RR1-3/4 1M	1 1/4" Roll Staple
/971601-5057	RR5-5/8 5M	1 1/4" Roll Staple
/971601-5058	RR5-3/4 5M	1 1/4" Roll Staple

Bostitch Style Staples

No.	Desc.	Crown Type
/971602-1022	SW-7437 5/8	1 11/32" B Staple
/971602-1023	SW-7437 3/4	1 11/32" B Staple
/971602-1042	SW-9040 5/8	1 11/32" BA Staple
/971602-1043	SW-9040 3/4	1 11/32" BA Staple
/971602-1044	SW-9040 7/8	1 11/32" BA Staple
/971300	SWC-7437- 1/2-1M	1 11/32" B Staple Coil
/971306	SWC-7437- 1/2-4M	1 11/32" B Staple Coil

No.	Desc.	Crown Type
/971309	SWC-7437- 5/8-1M	1 11/32" B Staple Coil
/971310	SWC-7437- 5/8-4M	1 11/32" B Staple Coil
/971311	SWC-7437- 3/4-1M	1 11/32" B Staple Coil
/971312	SWC-7437- 3/4-4M	1 11/32" B Staple Coil

IDEAL Wire Stitchers Standard Crown 7/16"

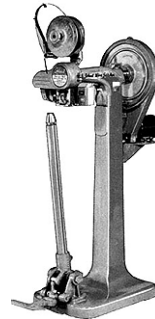

Standard Crown 7/16"

Staple shipping container bottoms. Bring post into position and actuate clencher head in one operation. Staples produced from wire coil. Conform with Uniform Freight Classification, Rule 41 and by the National Container Committee.

Standard Crown 7/16". Uses wire size .020x.103 and other standard wires.

No.	Clinching Point To Frame	Post Ht.	Max. Box Wdth.	Ship. Wt. Lbs.
...IB 1240	12	40	24	470
...IB 2043	20	43	40	620
...IB 2540	25	40	50	650

Note: Also Available - Wide Crown 1 1/8". Uses wire size .037x.074.

STITCHING WIRES

50 lbs./pkg. Other sizes available.

No.	Size	Desc.	Approx. Lbs.	Pkg. Qty.
/970605-1243	.02"x.103"	Copper Coated	10	5
/970605-1343	.02"x.103"	Copper Coated	25	2
/970605-2243	.02"x.103"	Galv. Coated	10	5
/970605-2343	.02"x.103"	Galv. Coated	25	2
/970605-1311	.074"x.0375"	Copper Coated	25	2
/970025	.06"x.0205"	#1 Hybar	10	5
/970030	.06"x.024"	#2 Hybar	10	5
/970035	.06"x.028"	#3 Hybar	10	5
/970050	18-HC	GR 260	10	5

STRIP NAILS

Clipped Head



Following for use in Senco SNII, SNIII, SNIV, SN325+ and SN70, Semco Pro 600/

650, Paslode 5300, F350S, 5325, 5350, IM325, SK-312 and GN238, Porter Cable FC350, Hitachi NR83AA, Tech Forge 1517, 1521 and 1524, and Stan Tech SDN11PTB-1 nailers.

No.	Model No.	Size In.	Desc.	Box Qty. M
/993679-5601	GC21	2x.113	Smooth	5
/993679-5701R	GE21	2x.113	Ring	5
/993679-5701RG	GE21	2x.113	Ring Galv.	5
/993679-5601G	GE21	2x.113	Galv.	5
/993679-5613H	GC23	2 1/4x.113	Hard Steel	5
/993679-5613HJUG	GC23	2 1/4x.113	Hard Steel	2.5
/993679-5613	GC24	2 3/8x.113	Smooth	5
/993679-5731R	GE24	2 3/8x.113	Ring	5
/993679-5731RG	GE24	2 3/8x.113	Ring Galv.	5
/993679-5731RSS	...	2 3/8x.113	Ring SS	1
/993679-5813G	GC24	2 3/8x.113	Galv.	5
/993679-5636	HC27	3x.121	Smooth	2.5
/993679-5604	KC27	3x.131	Smooth	2.5
/993679-5704R	HE27	3x.121	Ring	2.5
/993679-5704RG	HE27	3x.121	Ring Galv.	2.5
/993679-5704RSS	...	3x.121	Ring SS	1
/993679-5804G	HC27	3x.128	Galv.	2.5
/993679-5605	KC28	3 1/4x.131	Smooth	2.5
/993679-5705R	HE28	3 1/4x.121	Ring	2.5
/993679-5705RG	HE28	3 1/4x.121	Ring Galv.	2.5
/993679-5805G	HC28	3 1/4x.121	Galv.	2.5
/993679-5705SS	...	3 1/4x.121	Smooth SS	1
/993679-5606	KC29	3 1/2x.131	Smooth	2.5

Following for use in Bostitch N-16CT, N-70S-1 and N-80S-1, Atro H90 CHN and Campbell Hausfeld NS289000-NS289099 nailers.

No.	Model No.	Size In.	Desc.	Box Qty. M
/993679-5651	S6D	2x.113	Smooth	2
/993679-5751R	S6D	2x.113	Ring	2
/993679-5751RG	S6D	2x.113	Ring Galv.	2
/993679-5663H	S7DH	2 1/4x.113	Hard Steel	2
/993679-5663	S8D	2 3/8x.113	Smooth	2
/993679-5763R	S8D	2 3/8x.113	Ring	2
/993679-5763RG	S8D	2 3/8x.113	Ring Galv.	2
/993679-5763RSS	S8DRSS	2 3/8x.113	Ring SS	1
/993679-5863G	S8D	2 3/8x.113	Galv.	2
/993679-5653	S10D	3x.121	Smooth	2
/993679-5654	S10D	3x.131	Smooth	2
/993679-5754R	S10D	3x.121	Ring	2
/993679-5754RG	S10D	3x.121	Ring Galv.	2
/993679-5854G	S10D	3x.121	Galv.	2
/993679-5655	S12D	3 1/4x.131	Smooth	2
/993679-5855RG	S12D	3 1/4x.121	Ring Galv.	2
/993679-5855G	S12D	3 1/4x.121	Galv.	2
/993679-5855SS	S12DSS	3 1/4x.121	SS	1
/993679-5656	S16D	3 1/2x.131	Smooth	2

COIL NAILS

Mini

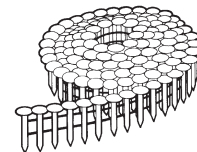

For use in Hitachi NV50A1, Atro 50 and 60, Senco SCN 200 nailers.

No.	Size In.	Desc.	Box Qty.
/993121-3237	1 1/4x.082	Ring	15.12M
/993121-3831	1 1/2x.082	Screw	12.96M
/993121-4531	1 3/4x.082	Screw	10.8M
/993121-4538	1 3/4x.082	Ring Galv.	10.8M

COIL NAILS
Full Head

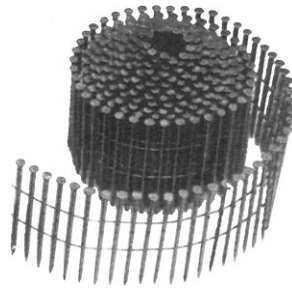

Following for use in Hitachi NV83A and NV65AC, Bostitch N70C, N80C, N86C and N100C, Atró 75/80/85, Senco SCN300, SCN60, and SCN65, Hilti and Stan Tech SDCN12B-1 nailers.

No.	Model No.	Size In.	Desc.	Box Qty.
/993645-3595	...	1 3/4 x .113	Ring	4.5M
/993645-3602	AC6DS	2 x .099	Screw	7.2M
/993645-3606	AC6DR113	2 x .113	Ring	4.5M
/993645-3607	AC6DR113G	2 x .113	Ring Galv.	4.5M
/993645-3615	AC7DS	2 1/4 x .099	Screw	7.2M
/993645-3620	...	2 1/4 x .121	Hard Steel	4.5M
/993645-3624	AC8D	2 3/8 x .113	Smooth	4.5M
/993645-3610FAL	AC8DR	2 3/8 x .113	Ring	4.5M
/993645-3611FAL	AC8DRG	2 3/8 x .113	Ring Galv.	4.5M
/993645-3616	AC8DS	2 1/2 x .099	Screw	7.2M
/993645-3630	AC10D	3 x .121	Smooth	4.5M
/993131-7530	AC10DS	3 x .120	Screw	4.5M
/993645-3635	AC10DSG	3 x .121	Screw Galv.	4.5M
/993645-3642	AC12D	3 1/4 x .121	Smooth	4.5M
/993645-3643	AC12DSG	3 1/4 x .121	Screw Galv.	4.5M

Hitachi brand.

No.	Size In.	Desc.	Box Qty.
/99312205	2 x .099	Screw - Blunt Pt.	9M
/99312206	2 1/4 x .099	Screw - Blunt Pt.	9M
/99312218	2 1/2 x .099	Screw - Blunt Pt.	9M
/99312219	2 3/8 x .099	Ring	9M
/99312207	2 3/8 x .099	Ring Galv.	9M
/99312213	3 x .120	Smooth	4M
/99312215	3 1/4 x .120	Smooth	4M

Following for use in Atró Roll 65/70, Senco SCN250D and Hilti RC212B nailers.

No.	Size In.	Desc.	Box Qty.
/993125-4531	1 3/4 x .099	Screw	12M
/993125-5031	2 x .099	Screw	9.6M
/993125-5731	2 1/4 x .099	Screw	9.6M
/993125-6530	2 1/2 x .099	Screw	7.2M

Following for use in Paslode C0212, 4250C, 5250C, 5300C and 5350C nailers.

No.	Size In.	Desc.	Box Qty.
/993403070FAL	2 x .099	Screw	7.2M
/993403071FAL	2 1/4 x .097	Screw	7.2M

COIL NAILS
Roofing

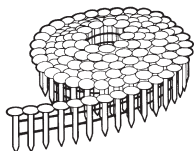

For use in Hitachi, Tech, Atró, Bostitch, Senco and Stan Tech SDCN10B-1 nailers.

No.	Model No.	Size In.	Desc.	Box Qty.
/993131-2525TAW	12100	1 x .120	Galv.	7.2M
/993131-3225	12101	1 1/4 x .120	Galv.	7.2M
/993131-3825	12102	1 1/2 x .120	Galv.	7.2M

COIL NAILS
Concrete



For use in Hitachi NC65AC nailer.

No.	Model No.	Size In.	Desc.	Box Qty.
/993CRN08G	...	1 x .120	Galv.	7.2
/993CRN10G	...	1 1/4 x .120	Galv.	7.2
/993CRN12G	...	1 1/2 x .120	Galv.	7.2
/993CRN14G	...	1 3/4 x .121	Galv.	7.2

Our order desk is always ready to assist you.

No.	Size In.	Desc.	Box Qty.
/99313200	1 x .145	Smooth	1M
/99313201	1 1/4 x .145	Smooth	1M
/99313202	1 1/2 x .145	Smooth	1M
/99313203	1 3/4 x .145	Smooth	1M
/99313204	2 x .145	Smooth	1M
/99313205	2 1/4 x .145	Smooth	1M
/99313206	2 1/2 x .145	Smooth	1M



6863 Commerce Drive
Next To I-80
Hubbard, Ohio 44425

Phone: (330) 534-8171
Fax: (330) 534-8179
Toll Free: (800) 533-8171

STRIP NAILS

Full Head

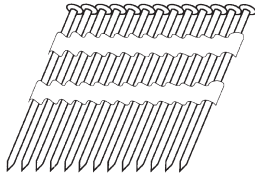

Following for use in Atró Helen 90.

Nails with SPC Suffix. Also for use in Duo-fast clipped head nailer CN325.

No.	Model No.	Size In.	Desc.	Box Qty.
/993129-6500SPC		2 3/8x.113	Smooth	5M
/993133-7500SPC		3x.131	Smooth	4M
/993133-9000SPC		3 1/2x.131	Smooth	4M

Following for use in Duofast CN137 and CN350, Haubold, Hitachi NR83A, Senco SN60, Makita AN8300, Porter Cable FR350, Campbell Hausfeld NS209000 and Stan Tech SDN11B-1 nailers.

No.	Model No.	Size In.	Desc.	Box Qty.
/99310100S	29	2x.113	Screw	6M
/99310102	7	2 3/8x.113	Smooth	5M
/99310103	...	2 3/8x.113	Ring	5M
/99310102S212	16	2 1/2x.113	Screw	5M
/99310112	...	2 3/8x.113	Ring Galv.	5M
/99310105	301	3x.120	Smooth	4M
/99310110	...	3x.131	Smooth	4M
/99310110S	15	3x.131	Screw	4M
/99310106	...	3x.120	Screw Galv.	4M
/99310111	24	3 1/4x.131	Smooth	4M
/99310119	409G	3 1/4x.120	Screw Galv.	4M
/99310120	46	3 1/2x.131	Smooth	4M
/99310120S	...	3 1/2x.121	Screw	4M

FINISH STAPLES

Narrow Crown - Galvanized - 18-Ga.



Following for use in Senco L, Atró 90, Tech Forge, Duofast 1800, BEA 90-190, Hitachi N3804A, Porter Cable NS100 and Spotnail FS4825 staplers.

No.	Model No.	Size In.	Box Qty.	Box/ Ctn.
/992677-4483	L-06	3/8	5M	20
/992677-4484PRE	L-08 (EB-12)	1/2	8M	5
/992677-4485PRE	L-10 (EB-16)	5/8	8M	5
/992677-4486PRE	L-11 (EB-19)	3/4	4M	10
/992677-4487PRE	L-12 (EB-22)	7/8	4M	10
/992677-4487D	L-12 (4807DE)	7/8	5M	10
/992677-4488PRE	L-13 (EB-25)	1	4M	10
/992677-4489PRE	L-14 (EB-28)	1 1/8	4M	10
/992677-4490PRE	L-15 (EB-32)	1 1/4	4M	10
/992677-4490SS	Stainless	1 1/4	2.5M	10
/992677-4491SPO	Nylon Coated	1 3/8	5M	6
/992677-4492PRE	L-17 (EB-38)	1 1/2	4M	10

Following for use in Paslode staplers.

No.	Model No.	Size In.	Box Qty.	Box/ Ctn.
/992677-4450	GSN18	1/2	5M	10
/992677-4450PRE	GSN18 (EF-12)	1/2	10M	5
/992677-4451PRE	GSN18 (EF-16)	5/8	10M	5
/992677-4452	GSN18	3/4	5M	10
/992677-4452PRE	GSN18 (EF-19)	3/4	10M	5

No.	Model No.	Size In.	Box Qty.	Box/ Ctn.
/992677-4453	GSN18 (EF-22)	7/8	5M	10
/992677-4454	GSN18 (EF-25)	1	5M	10
/992677-4455	GSN18 (EF-28)	1 1/8	5M	10
/992677-4457	GSN18 (EF-32)	1 1/4	5M	10
/992677-4460	GSN18 (EF-38)	1 1/2	5M	10

Following for use in Bostitch S3297-LHF (flooring) stapler.

No.	Model No.	Size In.	Box Qty.	Box/ Ctn.
/992097-2500	SB97-1G (P97-25)	1	5M	20

Following for use in Bostitch, Spotnail and Hilti 8308-8318 staplers.

No.	Model No.	Size In.	Box Qty.	Box/ Ctn.
/992300-0013	SJ5035 (3807)	7/8	5M	10
/992300-0013PRE	SJ5035 (3807, EK-22)	7/8	4M	10
/992300-0013D	SJ5035 (3807DE)	7/8	5M	10
/992300-0015	SJ5035 (3809)	1 1/8	5M	10
/992300-0015PRE	SJ5035 (3809, EK-28)	1 1/8	4M	10

Following for use in Bostitch staplers.

No.	Model No.	Size In.	Box Qty.	Box/ Ctn.
/992300-0020	SX5035 (K-12)	1/2	5M	10
/992300-0021	SX5035 (K-16)	5/8	5M	10
/992300-0022	SX5035 (K-19)	3/4	5M	10
/992300-0023	SX5035 (K-22)	7/8	5M	8/10
/992300-0024	SX5035 (K-25)	1	5M	8/10
/992300-0026	SX5035 (K-30)	1 3/16	5M	6/10

Following for use in 97 Atró and Senco K staplers.

No.	Model No.	Size In.	Box Qty.	Box/ Ctn.
/992300-0020PRE	K-08 (EX-12)	1/2	6.5M	20
/992300-0021PRE	K-10 (EX-16)	5/8	6M	20
/992300-0022PRE	K-11 (EX-19)	3/4	4M	20
/992300-0023PRE	K-12 (EX-22)	7/8	4M	20
/992300-0024PRE	K-13 (EX-25)	1	4M	20
/992300-0026PRE	K-15 (EX-30)	1 3/16	2M	20

SHEATHING STAPLES

Medium Crown - Galvanized - 16-Ga.

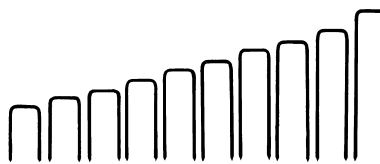

Following for use in Senco N, Atró 100, Hitachi N5008AB-AA-A1, BEA and Power-line staplers.

No.	Model No.	Size In.	Box Qty.
/992110-1800	N-11 (L-19)	3/4	20M
/992110-2200	N-12 (L-22)	7/8	10M
/992110-2500	N-13 (L-25)	1	10M
/992110-2800	N-14 (L-28)	1 1/8	10M
/992110-3200	N-15 (L-32)	1 1/4	10M
/992110-3800	N-17 (L-38)	1 1/2	10M
/992110-3800SS	Stainless	1 1/2	10M
/992110-4500	N-19 (L-44)	1 3/4	10M
/992110-5000	N-21 (L-50)	2	10M

Following for use in Bostitch, Atró 16NC, Spotnail and Hilti staplers.

No.	Model No.	Size In.	Box Qty.
/992116-2500	BCS1105	1	20M
/992116-2500PRE	BCS1105 (S-25)	1	10M
/992116-3200	BCS1107 (S-32)	1 1/4	10M
/992116-3800	BCS1109 (S-38)	1 1/2	10M
/992116-4500	BCS1111 (S-44)	1 3/4	10M
/992116-5000	BCS1112 (S-50)	2	10M

Following for use in Paslode and Tech Forge staplers.

No.	Model No.	Size In.	Box Qty.
/992677-2688	GS16 (GX-25)	1	10M
/992677-2690	GS16 (GX-32)	1 1/4	10M
/992677-2692	GS16 (GX-38)	1 1/2	10M
/992677-2694	GS16 (GX-44)	1 3/4	10M
/992677-2696	GS16 (GX-50)	2	10M

Following for use in Duofast, Haubold and Paslode GS116 staplers.

No.	Mfr. No.	Size In.	Box Qty.
/992677-2288	7632 (Z-25)	1	15M
/992677-2290	7640 (Z-32)	1 1/4	10M
/992677-2292	7648 (Z-38)	1 1/2	10M
/992677-2294	7656 (Z-44)	1 3/4	10M
/992677-2296	7664 (Z-50)	2	10M

STAPLES

Medium Crown - Galvanized - 15-Ga.

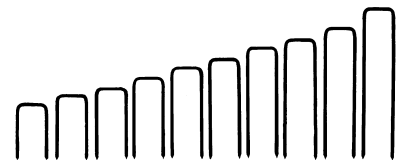

Following for use in Senco M3 and Powerline staplers.

No.	Model No.	Size In.	Box Qty.
/992677-1092	Q-17	1 1/2	10M
/992677-1092INT	Q-17 (Q-38)	1 1/2	5M
/992677-1094	Q-19	1 3/4	10M
/992677-1094INT	Q-19 (Q-44)	1 3/4	5M
/992677-1096	Q-21 (Q-50)	2	5M
/992677-1098	Q-23 (Q-56)	2 1/4	5M
/992677-1100	Q-25 (Q-63)	2 1/2	5M

Following for use in Paslode staplers.

No.	Model No.	Size In.	Box Qty.
/992677-0096	GS15 (GZ-50)	2	5M
/992677-0098	GS15 (GZ-56)	2 1/4	5M

Following for use in Bostitch and Spotnail 7516PG staplers.

No.	Model No.	Size In.	Box Qty.
/992118-3800PRE	BCS1512 (SB-38)	1 1/2	7.5M
/992118-4500	BCS1514 (SP-45)	1 3/4	10M
/992118-5000	BCS1516 (SB-50)	2	5M
/992118-5000SPO	...	2	5M

ROOFING STAPLES

Wide Crown - Galvanized - 16-Ga.

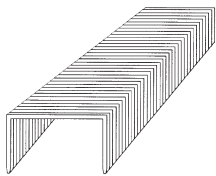

Following for use in Senco, Hitachi N3824A, Duofast 1700 and Arrow HT65S (3/4" only) staplers.

No.	Model No.	Size In.	Box Qty.
/992677-3485	P-10BAB (WS-16)	5/8	10M
/992677-3486	P-11BAB (WS-19)	3/4	10M
/992677-3487	P-12BAB (WS-22)	7/8	10M
/992677-3488	P-13BAB (WS-25)	1	10M
/992677-3490	P-15BAB (WS-28)	1 1/4	10M
/992677-3492PRE	P-17BAB (WS-32)	1 1/2	5M

Following for use in Bostitch, Atro 16WC, Spotnail, BEA and Berryfast staplers.

No.	Model No.	Size In.	Box Qty.
/992119-1500	BCS1096 (WC-16)	5/8	10M
/992119-1800	BCS1097 (WC-19)	3/4	10M
/992119-2200	BCS1098 (WC-22)	7/8	10M
/992119-2500	BCS1099 (WC-25)	1	10M
/992119-3200	BCS1101 (WC-32)	1 1/4	10M
/992119-3800PRE	BCS1102 (WC-38)	1 1/2	5M

Following for use in Paslode staplers.

No.	Model No.	Size In.	Box Qty.
/992677-3686	GSW16 (WT-19)	3/4	10M
/992677-3687	GSW16 (WT-22)	7/8	10M
/992677-3688	GSW16 (WT-25)	1	10M
/992677-3690	GSW16 (WT-32)	1 1/4	10M
/992677-3692PRE	GSW16 (WT-38)	1 1/2	5M

Following for use in Hilti and Haubold 25 staplers.

No.	Model No.	Size In.	Box Qty.
/992677-3788	BK2525, WS 6116 (WD-25)	1	10M
/992677-3790	BK2532, WS 6120 (WD-32)	1 1/4	10M
/992677-3792PRE	BK2538, WS 6124 (WD-38)	1 1/2	5M

HOG RINGS



No.	Desc.	Box Qty.	Box/ Ctn.
/99215N50P	15-Ga., 3/4"	10M	1
/99215N50PFAL	15-Ga., 3/4"	20M	1
/992680-2305	HR22, 7/8"	19.8M	1
/992680-2306	HR30, 1"	14M	1
/992680-2306SPE	HR30, 1"	10M	1
/960SR8062SP	SR8-062SP, Blunt Pt.	2.5M	10
/99209AL25	9-Ga. Aluminum	2.5M	1

CORRUGATED FASTENERS

24-Ga.

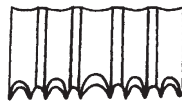

Width 1". For use in Atro CF, BEA, Duofast and Spotnail staplers.

No.	Model No.	Size In.	Box Qty.	Box/ Ctn.
/992122-1000	CF10	3/8	1.5M	9
/992122-1000PRE	CF10 (WN-9)	3/8	7.5M	1
/992122-1300	CF13	1/2	1.2M	9
/992122-1300PRE	CF13 (WN-12)	1/2	6M	1
/992122-1300SPO	816	1/2	4M	1

WOODLOC FASTENERS

For use in Atro SM series.

No. 992668-5201. Also for use in Atro M series.

No.	Size No.	Size In.	Box Qty.	Box/ Ctn.
/992668-5201	1	1/2x1/2	5M	5
/992668-5202	2	3/4x1/2	2.5M	10

FINISH NAILS, BRADS & HEADLESS PINS

Straight 90°



Finish Nails. For use in Senco AX, Tech 1504-1503A, Duofast, Atro Tip Pin, BEA, Bostitch BT-50, Porter Cable BN200 and Spotnail CB1820 nailers. 18-ga.

Finish Nails

No.	Model No.	Size In.	Box Qty.	Box/ Ctn.
/994117-0100PRE	AX08 (J-12)	1/2	10M	10
/994117-0110PRE	AX10 (J-16)	5/8	10M	10
/994117-0120PRE	AX11 (J-19)	3/4	10M	10
/994117-0125	AX12 (J-22)	7/8	5M	10
/994117-0130	AX13 (J-25)	1	5M	10
/994117-0135	AX14 (J-30)	1 1/4	5M	10
/994117-0140	AX15 (J-32)	1 1/4	5M	10
/994117-0150	AX17 (J-38)	1 1/2	5M	10
/994117-0155	J-45	1 3/4	5M	10
/994117-0160	J-50	2	5M	10

Finish Nails. For use in Hitachi NT65A, Atro Tip, Paslode F-16, Duofast, Bostitch BT1200, Porter Cable FN250 and Spotnail FB1632 nailers. 16-ga.

Finish Nails

No.	Desc.	Size In.	Box Qty.	Box/ Ctn.
/994117-2000PRE	Galv. (N-19)	3/4	5M	10
/994117-2200PRE	Galv. (N-22)	7/8	5M	10
/994117-2500PRE	Galv. (N-25)	1	5M	10
/994117-3500PRE	Galv. (N-32)	1 1/4	5M	10
/994117-3500B	Bright (GB-16)	1 1/4	2M	10
/994117-4000PRE	Galv. (N-38)	1 1/2	2.5M	10
/994117-4000B	Bright (GB-16)	1 1/2	2M	10
/994117-4000SS	Stainless Steel	1 1/2	2.5M	12
/994117-4500PRE	Galv. (N-44)	1 3/4	2.5M	10
/994117-4500B	Bright (GB-16)	1 3/4	2M	10
/994117-5000PRE	Galv. (N-50)	2	2.5M	10
/994117-5000B	Bright (GB-16)	2	2M	10
/994117-5000SS	Stainless Steel	2	2.5M	12
/994117-5500PRE	Galv. (N-57)	2 1/4	2.5M	10
/994117-5500B	Bright (GB-16)	2 1/4	1.5M	10
/994117-6000PRE	Galv. (N-63)	2 1/2	2.5M	10
/994117-6000B	Bright (GB-16)	2 1/2	1.5M	10
/994117-6000SS	Stainless Steel	2 1/2	2.5M	12

Finish Brads. For use in Senco AY, Paslode F-18 and Hitachi NT45A nailers. 18-ga.

Finish Brads

No.	Model No.	Size In.	Box Qty.	Box/ Ctn.
/994117-0200PRE	AY08 (JM-12)	1/2	10M	20
/994117-0210PRE	AY10 (JM-16)	5/8	10M	20
/994117-0220PRE	AY11 (JM-19)	3/4	10M	20
/994117-0225PRE	AY12 (JM-22)	7/8	5M	20
/994117-0230	AY13 (JM-25)	1	5M	20
/994117-0240	AY15 (JM-32)	1 1/4	5M	20

Headless Pins. For use in Senco AZ, Paslode and Atro nailers. 18-ga.

Headless Pins

No.	Desc.	Size In.	Box Qty.	Box/ Ctn.
/994115-1500	I-15 (GA-16)	5/8	10M	10
/994115-2000	I-20 (GA-20)	3/4 (1 3/16)	10M	10
/994115-2500	I-25 (GA-25)	1	10M	10
/994115-3000	I-30 (GA-30)	1 1/4	13M	10

FINISH T-NAILS

Straight 90°

Following for use in Atro Panta 22D, Paslode, Bostitch, Powerline and BEA nailers.

No.	Desc.	Size In.	Box Qty.	Box/ Ctn.
-----	-------	----------	----------	-----------

Finish Head - 1/8"

/994679-5201	BT540B	1 1/4x.080	10M	1
/994679-5202	BT541B	1 1/2x.080	10M	1
/994679-5203	BT543B	1 3/4x.080	10M	1
/994679-5535	BT544B	2x.080	10M	1
/994679-5535G	Galv.	2x.080	10M	1
/994679-5539	...	2 1/2x.080	10M	1
/994679-5539G	Galv.	2 1/2x.080	10M	1
/994679-5150	...	2x.086	10M	1
/994679-5590	...	2 1/2x.097	10M	1

Regular Head - 1/4"

/994679-5111	...	1 1/4x.080	10M	1
/994679-5112	...	1 1/2x.080	10M	1
/994679-5113	...	1 3/4x.080	10M	1
/994679-5114	...	2x.080	10M	1
/994679-5100	...	1 1/2x.086	10M	1
/994679-5102	...	1 3/4x.086	10M	1
/994679-5103	...	2x.086	10M	1
/994679-5571HT	Heat Treated	3/4x.097	1M	10
/994679-5561HC	High Carbon	1 3/8x.097	10M	1
/994679-5561HT	Heat Treated	1 3/8x.097	10M	1
/994679-5122	...	2x.097	10M	1
/994679-5568HC	High Carbon	2 1/4x.097	10M	1
/994679-5124	...	2 1/2x.097	10M	1
/994679-5575HT	Heat Treated	3/4x.106	1M	10

Following for use in Spotnail and Duofast 8000 nailers. 15-ga.

No.	Model No.	Size In.	Box Qty.	Box/ Ctn.
/994117-7010	NG-44	1 3/4	3M	6
/994117-7015	NG-50	2	3M	6
/994117-7020	NG-63	2 1/2	3M	6

Following for use in Fasco and Duofast 8 nailers. 14-ga.

No.	Model No.	Size In.	Box Qty.	Box/ Ctn.
/994117-1406	ND-38	1 1/2	2.5M	6
/994117-1408	ND-44	1 3/4	2.5M	6
/994117-1410	ND-50	2	2.5M	6
/994117-1412	ND-63	2 1/2	2.5M	6
/994117-1416	ND-70	2 3/4	2.5M	6



FINISH NAILS

Angle

Following for use in Senco SFNI-II and SFN-40, Tech 1519-1518 and Porter Cable DA250 nailers.

No.	Model No.	Size In.	Desc.	Ga.	Box Qty.	Box/Ctn.
/994200-0014FAL	DA13	1	Bright	15	4M	4
/994200-0016FAL	DA15	1¼	Bright	15	4M	4
/994200-0017FAL	DA17	1½	Galv.	15	4M	4
/994200-0018FAL	DA17	1½	Bright	15	4M	4
/994200+0020FAL	DA19	1¾	Bright	15	4M	4
/994200-0021FAL	DA21	2	Galv.	15	4M	4
/994200-0022FAL	DA21	2	Bright	15	4M	4
/994200-0024FAL	DA23	2¼	Bright	15	4M	4
/994200-0027PRE	DA25	2½	Bright (DA-63)	15	4M	2
/994200-0025FAL	UA25	2½	Galv.	14	4M	1
/994200-0027	UA25	2½	Bright	14	4M	1

Following for use in Bostitch N60FN, Stan-Tech SDN15 and Makita nailers. 15-ga. Bright.

No.	Model No.	Size In.	Box Qty.	Box/Ctn.
/994200-1520	FN1520	1¼	3.5M	4
/994200-1524	FN1524	1½	3.5M	4
/994200-1528	FN1528	1¾	3.5M	4
/994200-1532	FN1532	2	3.5M	4
/994200-1536	FN1536	2¼	3.5M	4
/994200-1540	FN1540	2½	3.5M	4

Following for use in Bostitch N50FN and Atro Monza nailers. 16-ga. Bright.

No.	Model No.	Size In.	Box Qty.	Box/Ctn.
/994156-3200	FN1620	1¼	3.5M	8
/994156-3800	FN1624	1½	3.5M	7
/994156-4400	FN1628	1¾	3.5M	6
/994156-5000	FN1632	2	3.5M	5
/994156-5700	...	2¼	3.5M	4
/994156-6400	...	2½	3.5M	4

COMMON NAILS

Bright



Bulk nails. Wt. 50 lbs.

No.	Desc.	Lgth. In.	No. Pcs./Lb.
/965004	4D	1½	322
/965006	6D	2	196
/965008	8D	2½	104
/965010	10D	3	67
/965012	12D	3¼	63
/965016	16D	3½	40
/965018	20D	4	25
/965022	40D	5	18
/965026	60D	6	9

Note: Some sizes available in HDG.

Complete Information Available on Request.

BOX NAILS

Coated



Bulk nails. Wt. 50 lbs.

No.	Desc.	Lgth. In.	No. Pcs./Lb.
/965106	6D	2	232
/965108	8D	2¾	140
/965116	16D	3¾	71

SINKER NAILS

Coated



Bulk nails. Wt. 50 lbs.

No.	Desc.	Lgth. In.	No. Pcs./Lb.
/965206	6D	1¾	275
/965208	8D	2¾	142
/965210	10D	2¾	104
/965212	12D	3¼	77
/965216	16D	3¼	61

Complete Information Available on Request.

FINISH NAILS

Bright



Bulk nails. Wt. 50 lbs.

No.	Desc.	Lgth. In.	No. Pcs./Lb.
/965504	4D	1½	562
/965506	6D	2	267
/965508	8D	2½	162
/965510	10D	3	117
/965512	12D	3¼	101
/965516	16D	3½	85

Complete Information Available on Request.

DOUBLE HEADED NAILS

Duplex



Bulk nails. Wt. 50 lbs.

No.	Desc.	Lgth. In.	No. Pcs./Lb.
/965602	8D	2¼	88
/965606	16D	3	44

Complete Information Available on Request.

ROOFING NAILS

EG



Bulk nails. Wt. 50 lbs.

No.	Lgth. In.	No. Pcs./Lb.
/965612	¾	305
/965613	1	252
/965614	1¼	230
/965615	1½	189
/965616	1¾	165
/965617	2	156